



TYPE EXAMINATION CERTIFICATE

Certificate No :LS-B-0123/21
Identification Number of Notified body :2729
Name of Certificate Holder :DATIS TECHNOLOGY ALPHABET CO.
Manufacturer / Address TF137 section, No 0, 3rd narges street, Azadi avenue, Shams Abad industrial town, Hasan Abad, Fashapouyeh, Rey Tehran / IRAN
Date of Submission for Type-Examination :15.10.2019
Definition of Safety Component :INVERTER
Trademark :Xima
Type :Xima inverter
Applicable Directive/ Standards :EMC DIRECTIVE, 12015:2014, 12016:2013, 61000-4-2, 61000-4-6,61000-4-3, 61000-4-4, CISPR11/R.E., 61000-3-3, 61000-3-2,61000- 4-11
Examination Period : November 2022
Test Laboratory & place :ELDAŞ / Ankara / TURKEY
No & Date of laboratory Report :21.05.2019 / EMC19-0256
Documents annexed : Drawings, Calculations, Installation Manual
Field of application Load, speed : Annex1

Declaration - Additional Information

The Product should have a label with the necessary information.For all changes the certificate holder must inform the certification body.

Result of the examination and declaration

Hereby we confirm that the type of the product mentioned above, meets the requirements of the EMC DIRECTIVE. Only the products detailed in the test report have been subjected to tests.

Certificate Issue Date 18.11.2021
Validity Date 17.11.2022

General Director
Sebahattin ÇAY

Technical Responsible
Nasır ÖZÇELİK

GCNTR Uluslararası Belgelendirme Gözetim Eğitim ve Dış Tic. Ltd. Şti.
Kocaeli Kobi OSB 18. Cad. No:15 Dilovası – Kocaeli / TÜRKİYE
Tel: 0262 502 05 20 Fax: 0262 502 05 31 www.gcnturk.com / info@gcnturk.com

ANNEX 1

Annex of the Type examination certificate LS-B-0123/19

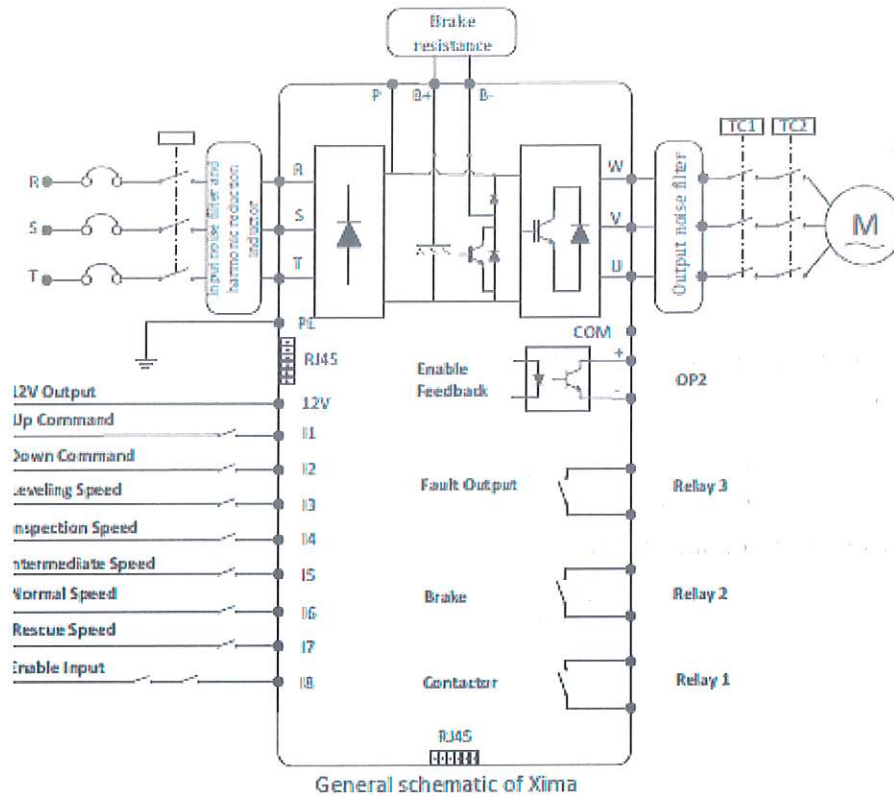

Place of installation

The installation of the product should be performed in environments that do not adversely affect the attributes of the materials used, protecting from harmful environmental factors (corrosion, chemicals, sunlight, high and low temperatures, etc.).